

Tecnologias de Ambiente, Lda.

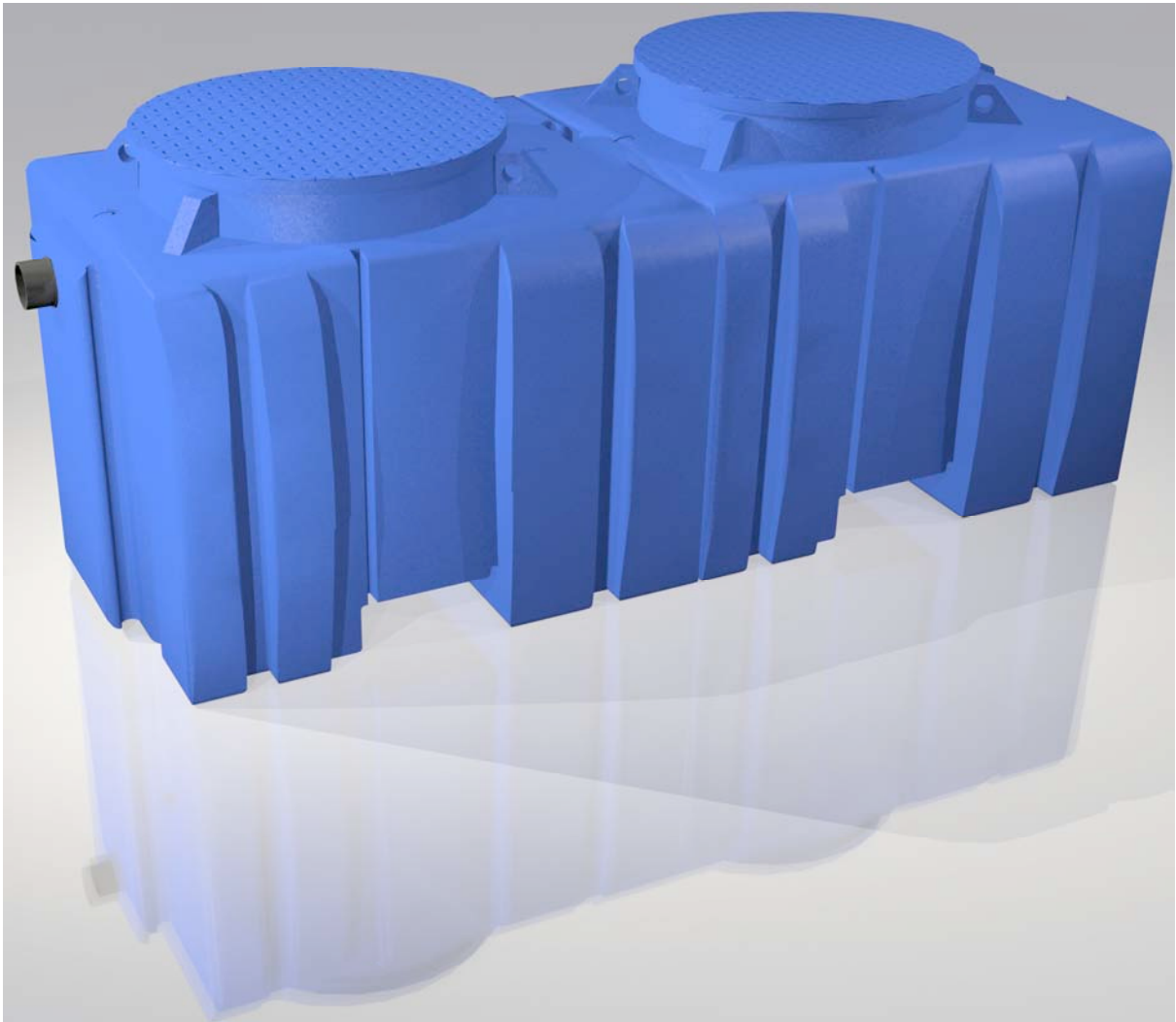

FOSSAS SÉPTICAS ALMAQUA

POLIETILENO ALTA DENSIDADE

Rua Parque Natural do Alvão, nº 59-A • Verdizela • 2855-620 Corroios
Tel.: 212 975 304 • Fax: 212 979 401 • www.almaqua.com

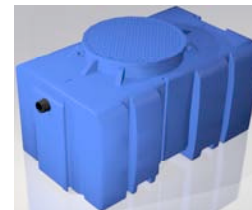

Tecnologias de Ambiente, Lda.

FOSSA SÉPTICA 1 500 LITROS

FS 1 500

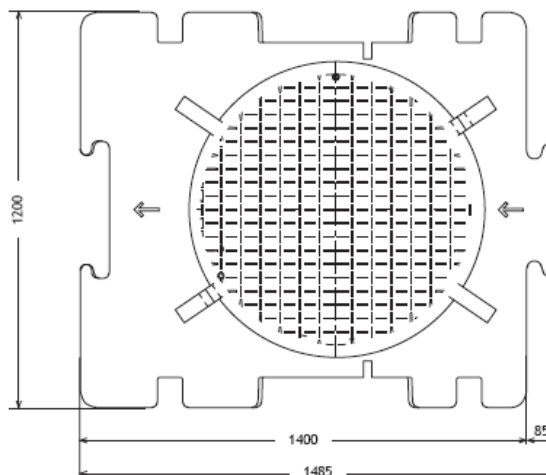
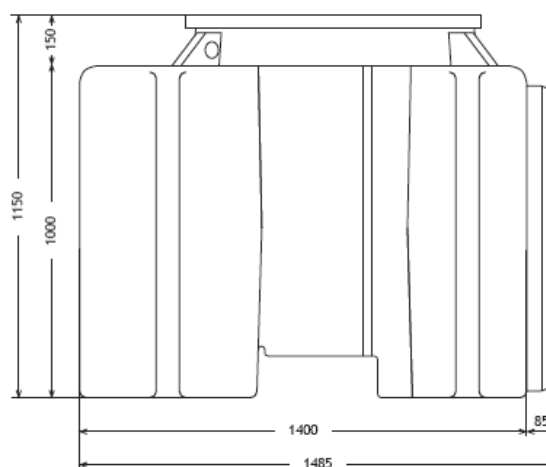
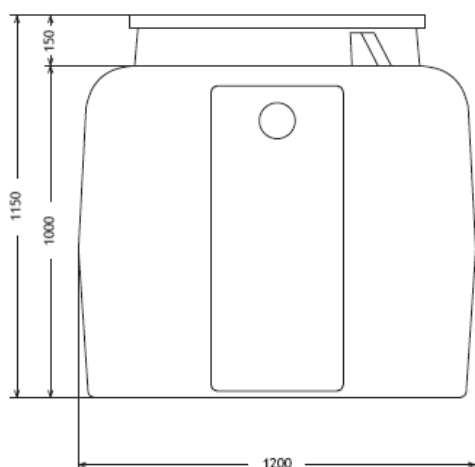

PEAD

MOD.	C (mm)	L (mm)	A (mm)	DN (mm)	Cap. (Litros)	Peso (Kg)
FS 1 500	1485	1200	1150	110	1500	80

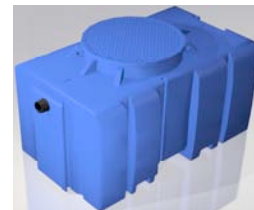

FOSSA SÉPTICA 2 000 LITROS

FS 2 000

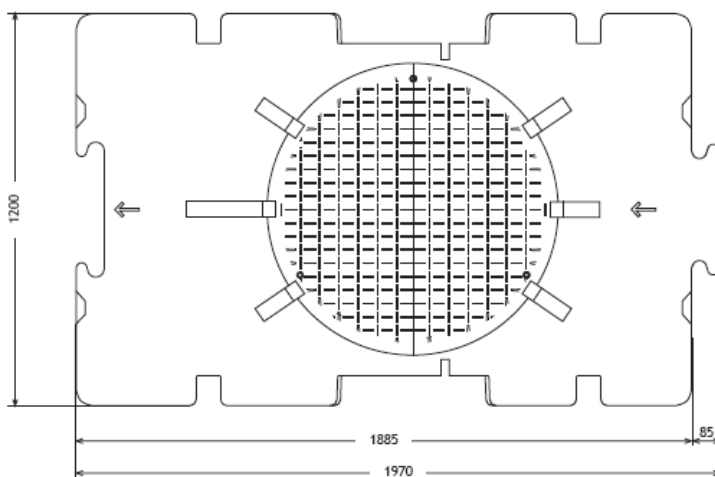
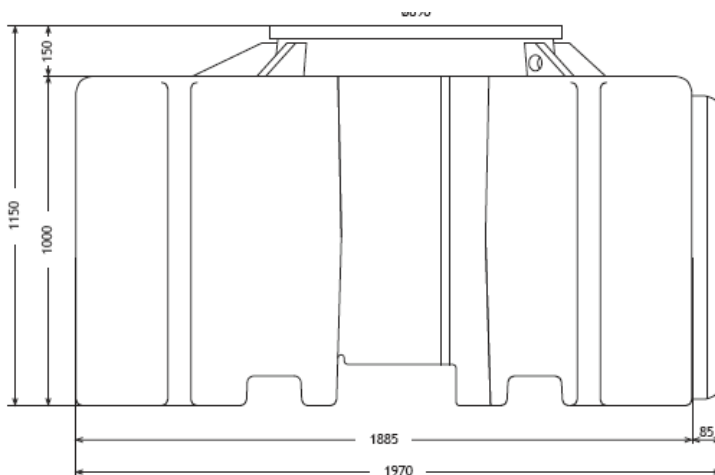
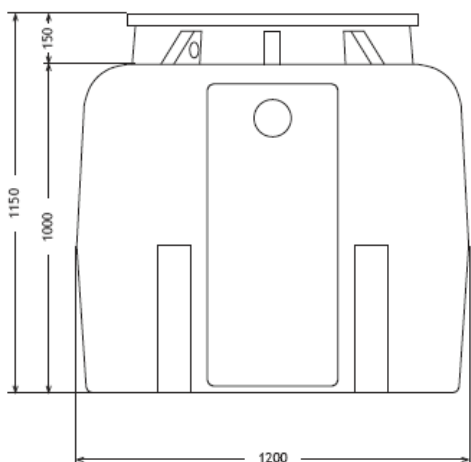

PEAD

MOD.	C (mm)	L (mm)	A (mm)	DN (mm)	Cap. (Litros)	Peso (Kg)
FS 2 000	1970	1200	1150	110	2000	90

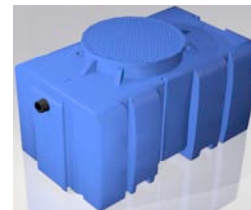

FOSSA SÉPTICA Bi-compartimentada

FS 3000

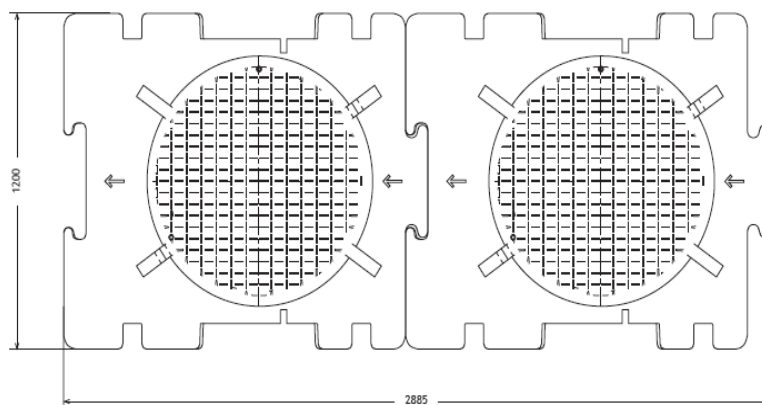
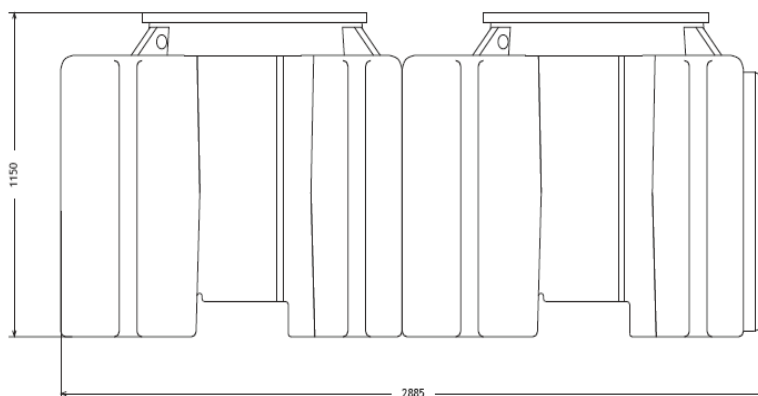
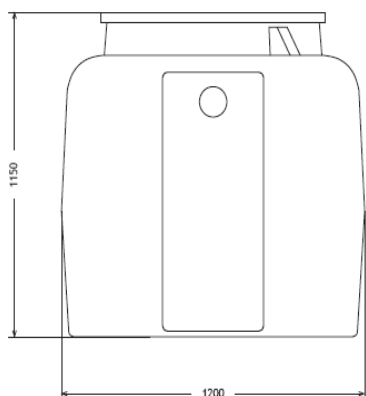

PEAD

MOD.	C (mm)	L (mm)	A (mm)	DN (mm)	Cap. (Litros)	Peso (Kg)
FS 3 000	2855	1200	1150	110	3 000	160

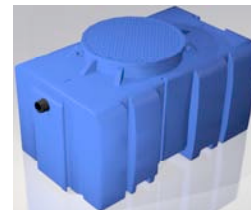

FOSSA SÉPTICA Bi-compartmentada

FS 3 500

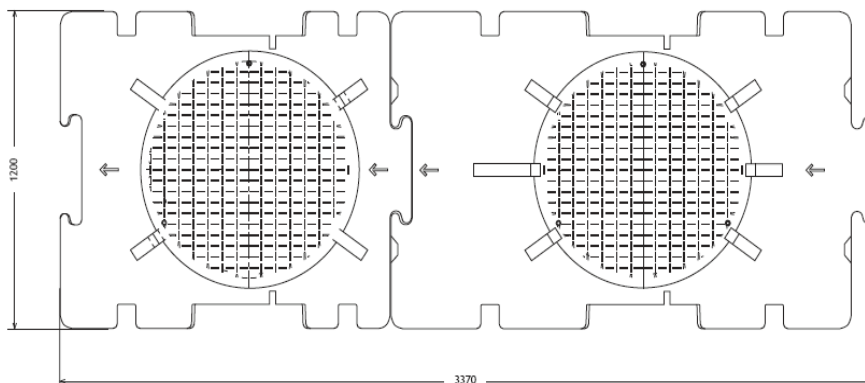
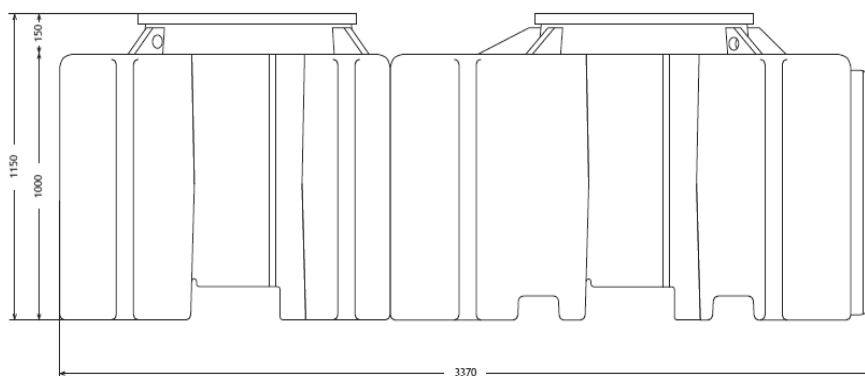
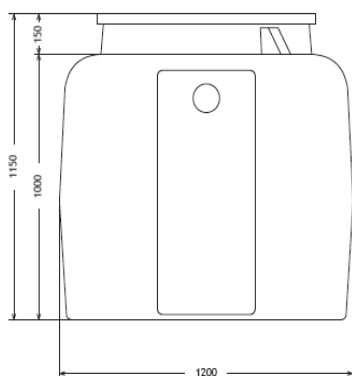

PEAD

MOD.	C (mm)	L (mm)	A (mm)	DN (mm)	Cap. (Litros)	Peso (Kg)
FS 3 500	3370	1200	1150	110	3 500	170

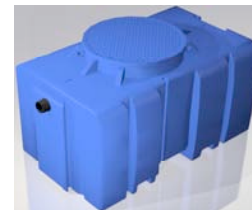

FOSSA SÉPTICA Bi-compartmentada

FS 4 000

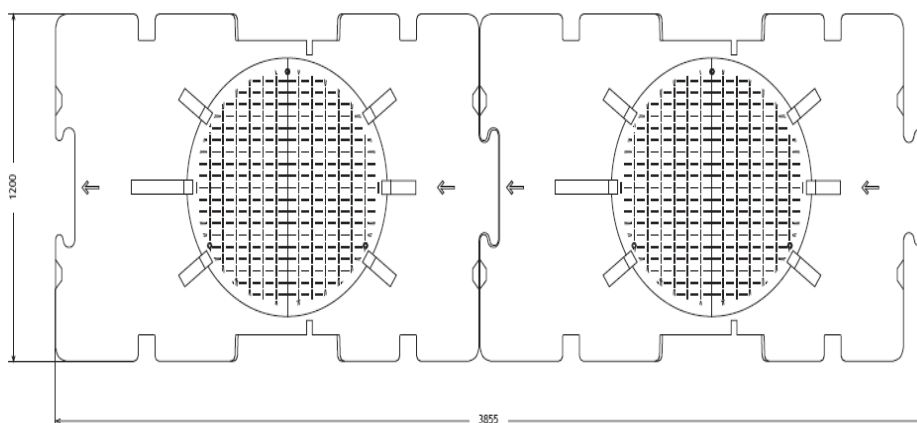
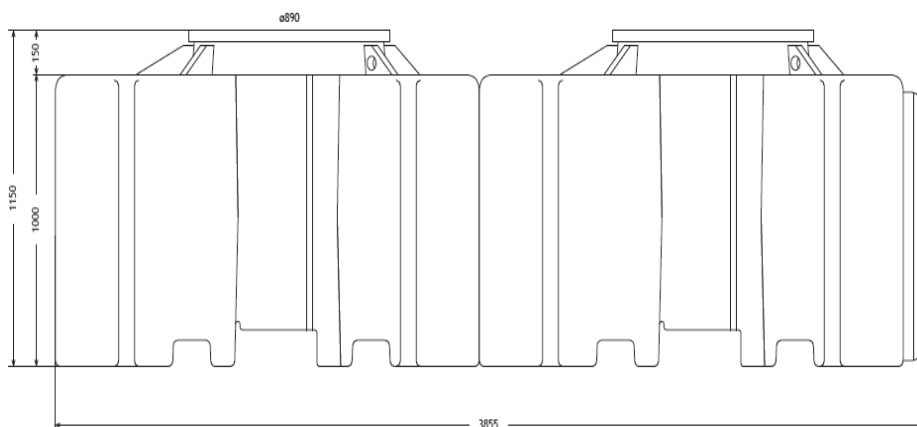
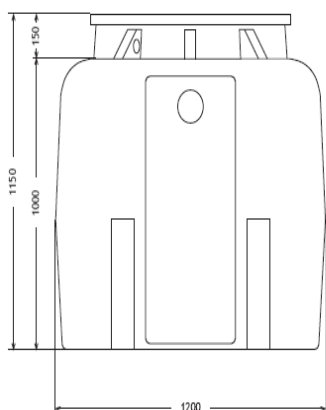

PEAD

MOD.	C (mm)	L (mm)	A (mm)	Cap. (Litros)	Peso (Kg)
FS 4000	3855	1200	1150	4 000	180

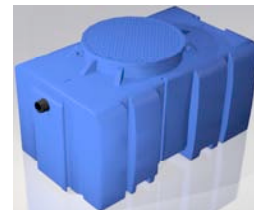

Tecnologias de Ambiente, Lda.

FOSSA SÉPTICA Tri-compartimentada

FS 4 500

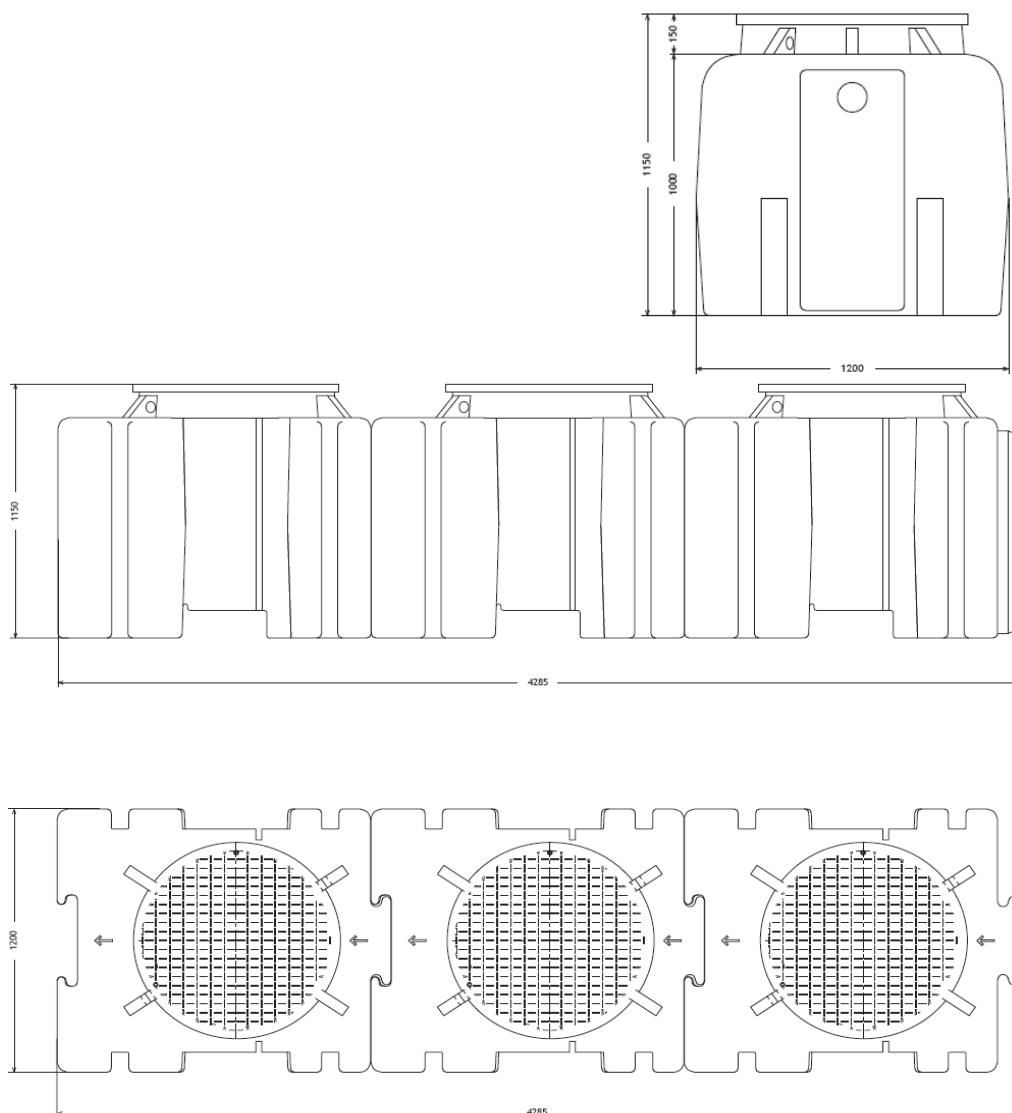

PEAD

MOD.	C (mm)	L (mm)	A (mm)	Dec. (Litros)	Peso (Kg)
FS 4 500	4285	1200	1150	4 500	240

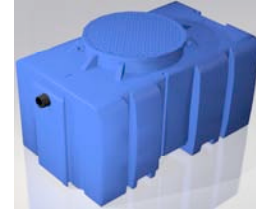

Tecnologias de Ambiente, Lda.

FOSSA SÉPTICA Tri-compartimentada

FS 5 500

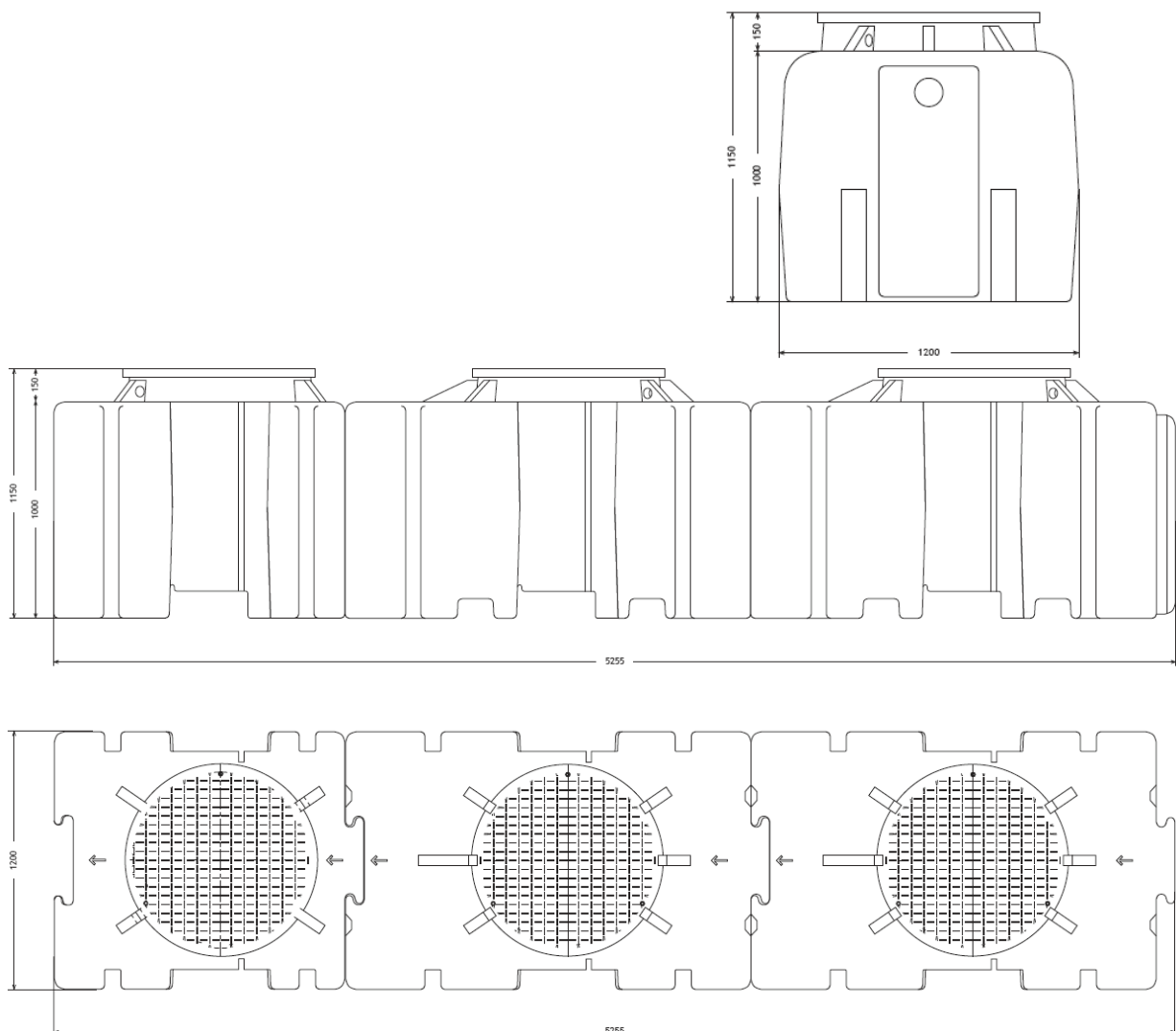

PEAD

MOD.	C (mm)	L (mm)	A (mm)	Dec. (Litros)	Peso (Kg)
FS 5 500	5255	1200	1150	5 500	260

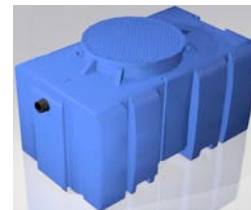

FOSSA SÉPTICA Tri-compartimentada

FS 6 000

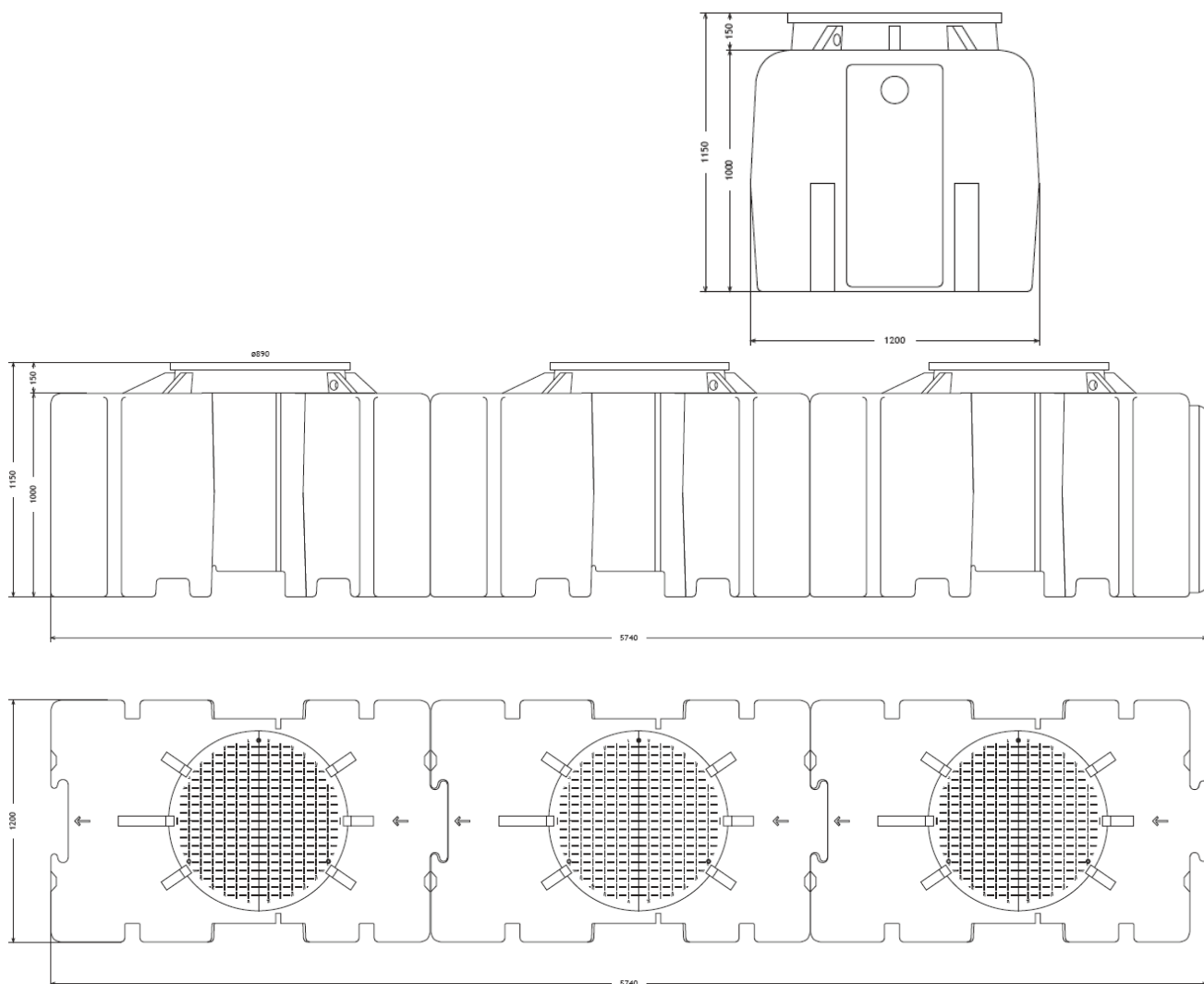

PEAD

MOD.	C (mm)	L (mm)	A (mm)	Dec. (Litros)	Peso (Kg)
FS 6 000	5740	1200	1150	6 000	270